

# Intersections of coarse shear bands in polystyrene

C. C. CHAU, J. C. M. LI

*Materials Science Program, Department of Mechanical and Aerospace Sciences, University of Rochester, Rochester, New York 14627, USA*

Three types of intersection between coarse shear bands are described. The first is the most numerous and happens in a single compression. The two bands shear each other. The reason why a new band can be sheared by an existing old band seems to be that it is easier for the new band to propagate along the striation direction of the old band rather than along its own direction. The merging of striations, the stretching of molecules, and the displacement of bands are described in some detail. The second type of intersection can be created by two mutually perpendicular compressions. As in the first type, the material inside the intersection is sheared twice, first by the old band and then by the new band. However, unlike the first, the two shears are in opposite directions in the second type of intersection. Both intersections cause sufficient disturbances so that microcracks and new shear bands (both coarse and fine bands) are generated to relieve some stresses. A third type of intersection which takes place also during two mutually perpendicular compressions has a small angle of intersection. The two shears of the material in the intersection are also in nearly opposite directions. However, the disturbance is so small that no microcracks or new shear bands are generated. As a result the bands offer little resistance to each other at the intersection of the third type. For all three types of intersection, the displacement of one band corresponds approximately to the shear strain of the other intersecting band. These observations suggest that molecular ordering or directional defects exist in the coarse shear bands in polystyrene.

## 1. Introduction

Two types of shear band were observed in atactic polystyrene by compression [1, 2], coarse and fine bands. The coarse bands were few in number, originated at stress concentrations, propagated fast for a long distance, and revealed themselves as dark, straight lines under the optical microscope. On the other hand, the fine bands were more numerous, spread slowly by multiplication rather than propagation, produced plastic strain, and were discernible only in the electron microscope as short segments. These bands represent different mechanisms of deformation because they obey different yielding criteria and respond differently to temperature, strain rate, and heat-treatment. Furthermore the coarse bands always led to shear fracture without much plasticity while

the fine bands led to ductile failure after considerable plastic strain. A study of the behaviour of these bands should help in the understanding of plastic deformation and failure of amorphous polymers.

After the initial characterization of the two types of shear bands and their yielding behaviours [1, 2], we reported [3] more recently in more detail the morphology of coarse bands, their surface profile, shear-strain distribution, splitting, joining, and terminating behaviour, and the effect of annealing and reformation on their appearances. We studied also the kinetics of shear-strain recovery of a thick coarse band [4] and measured the angles of intersection of coarse bands and their distributions [5]. This paper reports in detail the morphology of intersections between

coarse bands. The importance of shear-band intersections on shear-band fracture was pointed out recently by Friedrich and Schäfer [6] from the viewpoint of enhanced chain scission at intersections.

Some preliminary results on the intersection of coarse bands have been reported before [1]. While it was stated that coarse bands always shear each other at intersections, the reason behind it was not clear. Since it seemed unlikely that they all meet at the same time, it was speculated that the bands grow in thickness. Further studies [3] led us to believe that the bands did not grow in thickness, in agreement with Argon *et al.* [7] and Brady and Yeh [8]. They thicken only by joining of two or more bands. In searching for the reason for the mutual shearing at intersections, the following possibility seems inevitable. That is, when a shear band intersects a previously existing shear band, the new band not only shears the old band but also is sheared by it. This possibility can be verified by first producing one set of bands and then introducing another set to meet the first set. These experiments and others are described here.

## 2. Experimental procedure

Sheets of atactic polystyrene of 0.25 in. thick were obtained from Westlake Co. It was the same material as used previously [1]. As before, blocks cut from the sheets were annealed for 20 h at 115°C to remove internal stresses and moisture. They were furnace-cooled slowly to room temperature over a period of 7 h. Samples were then cut from the blocks by using a milling machine. All specimens were polished to 0.05 μm alumina finish. They were annealed again at 98°C for 16 h to remove cutting and polishing strains.

A single-stage replicating technique was used to make replicas for electron microscopy. This was the same as that used by Wu and Li [1] but with some modifications [3].

Other details will be described later with the results.

## 3. The first type of intersection

As mentioned in Section 1, it is necessary to verify the possibility that, when a shear band intersects an existing shear band, the new band not only shears the old band but also is sheared by it. The experimental procedure is shown in Fig. 1. A

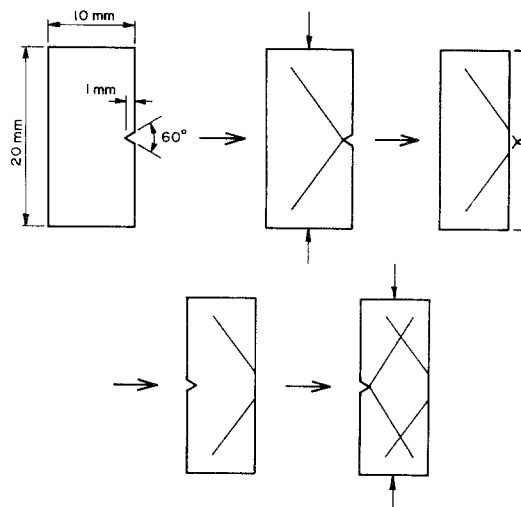


Figure 1 Experimental procedure for producing intersections of the first type by meeting an existing band packet with a new band packet.

notched sample of  $2 \times 1 \times 0.6 \text{ cm}^3$  was first compressed over its length in an Instron at a strain rate of  $0.05 \text{ sec}^{-1}$  until two shear-band packets were fully developed from the notch. Then the cross-head was raised at the same speed to remove the load. The specimen was then polished over emery paper for about 15 min to remove the notch. Based on previous experience, the removal of the notch will stop band propagation upon further compression.

Another notch of the same shape and size as the previous one was then cut at the other side of the specimen as shown schematically in Fig. 1. The specimen was compressed again as before until two new shear-band packets were developed and intersected the previous ones as also shown in Fig. 1. An actual photograph of the specimen at this stage is shown in Fig. 2. The intersection of the new and old packets is shown in Fig. 3: the long one is the old and the short segment is part of the new. It is seen that the above-mentioned possibility is confirmed, i.e. the new shear band not only shears the old band but also is sheared by it.

A careful comparison of Figs. 3 and 4 (the latter being the old band before the introduction of the new band) shows that the old shear-band packet did not propagate during the second compression. The fact that the old band can shear the new band suggests that the reason must come from the structure of the old band. A full view

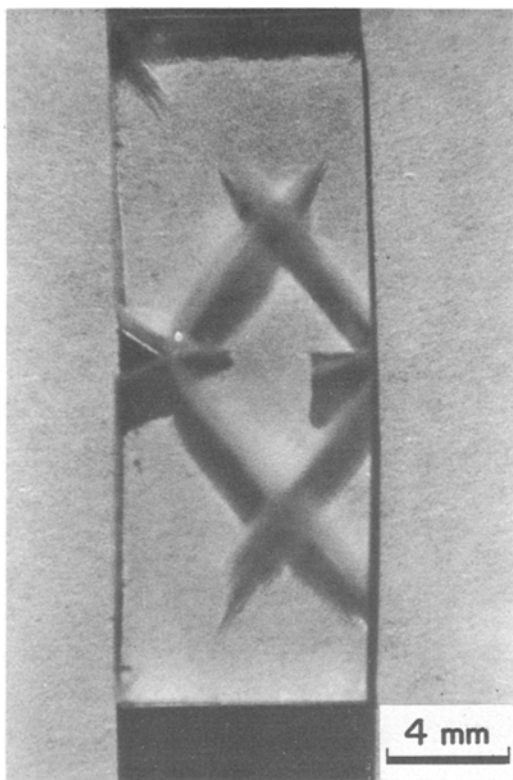


Figure 2 Intersecting band packets of the first type.

of the new band packet is shown in Fig. 5 and a larger magnification is shown in Fig. 6.

To examine the intersection more closely, replicas were made for observation in the electron microscope. A single-stage replication technique was used as before [3]. One of the intersections in Fig. 6 is greatly magnified in Fig. 7. The slip directions in each band can be obtained from the way that the other band is sheared. They can be revealed also by the displacement of the scratch marks. It is noted that, while the thickness of the old band is about the same on both sides of the intersection, the new bands are thicker on one side and thinner but more numerous on the other. Many thin bands were created by the intersection process.

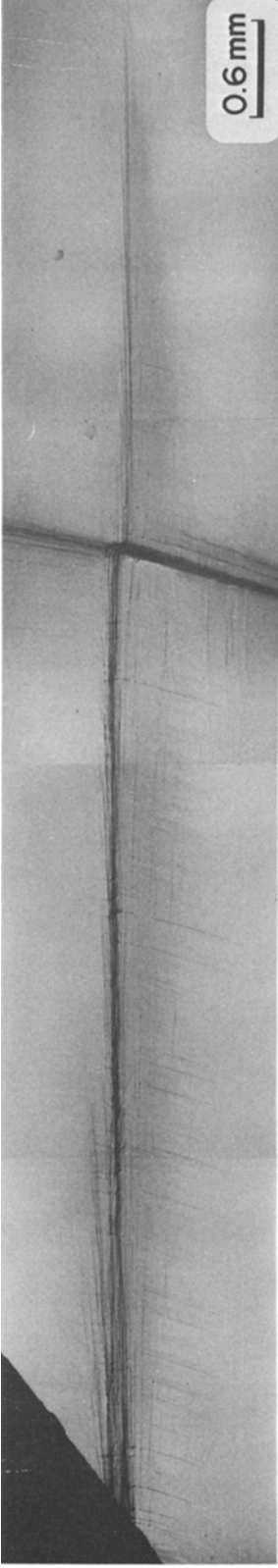
Another view of such intersection is shown in Fig. 8. The new band split into three bands before intersecting the first old band. Six new bands appeared after this intersection. These six encountered a pair of old bands and only four survived the intersection. These four encountered three more old bands and, after the intersections, combined into two bands. Considerable mutual straining took place at each intersection. Some

fine bands were generated to relieve some of the strains.

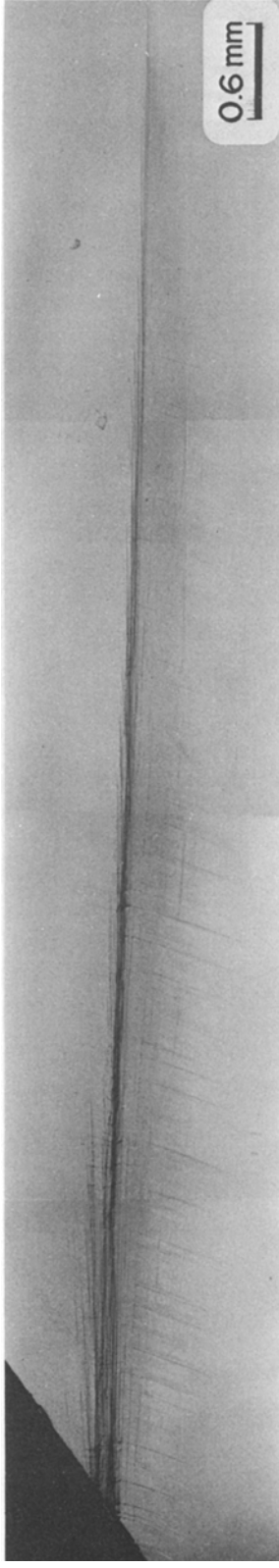
Fig. 9 is another view with details of striations in each band. Although the micrograph is not very clear, the striations appear to merge into one orientation at each intersection. This merging of striation directions is shown schematically in Fig. 10. Inspection of many electron micrographs reveals that the striation is always inclined towards the shear direction of the band. Each band is sheared by the other band, consistent with the striation direction of the latter. Hence the cause of the shearing of the new band by the old band seems to be related to the striations in the old band, i.e. the new band seems to be forced to propagate along the striation direction of the old band. Thus, it seems easier to shear inside the old band in the striation direction rather than in the new band direction. If the striations indicate the direction of molecular alignment in the band, this conjecture is consistent with the idea that it is easier to shear two parallel molecules along their common molecular direction than any other direction. This idea was used in explaining work-hardening of polyethylene deformed in tension [9].

Thus the merging of striations comes naturally when the new band attempts to propagate into the old band. When the two shear directions combine vectorially into a common direction in the intersection, the striation directions do likewise. The combined striation direction is  $A'B'$  as shown in Fig. 10. It results from the striation  $AB$  in the old band and a corresponding one in the new band. If the intersection is symmetric with respect to the intersecting bands, the direction  $A'B'$  is fixed at the plane of symmetry. Other striations such as  $CD$  and  $EF$  in the old band must move to the new locations  $C'D'$  and  $E'F'$ . While such motion is a simple displacement far away from the intersection, it has a rotational component inside the intersection with the largest rotation being the  $AB$  striation. The rotational motion arises because the displacement of the old band changes gradually from zero to its full extent through the intersection. As a result, the displacement of the two ends of a striation in the intersection may be different. This difference is the cause of rotation.

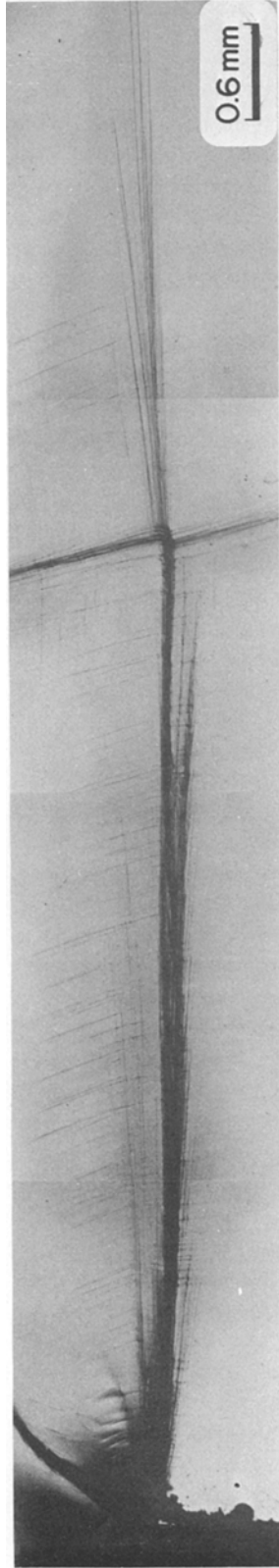
Because of the rotation, the length of striations may be increased after the intersection. Here again the largest increase is for the striation  $A'B'$ . For a symmetric intersection, this increase in length



*Figure 3* Surface features of the intersection of the new (short) and the old (long) shear band packets.



*Figure 4* The old shear band before intersection.



*Figure 5* A full view of the new shear-band packet intersecting the old packet.

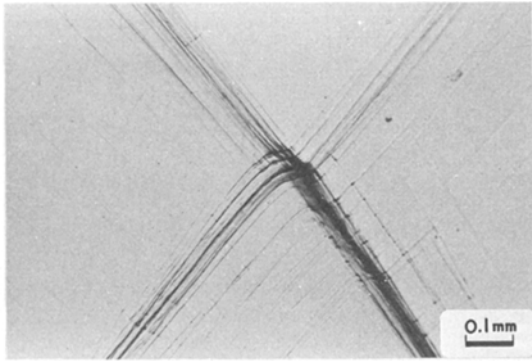


Figure 6 A magnified view of the first type of intersection.

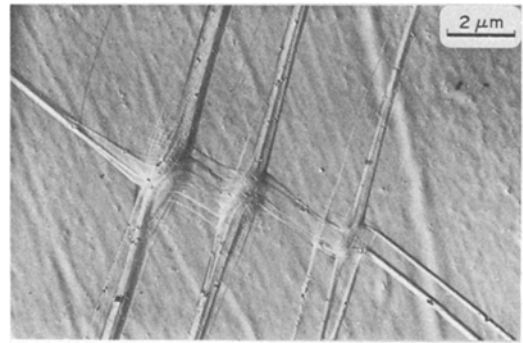


Figure 8 Electron micrograph of intersections of the first type.

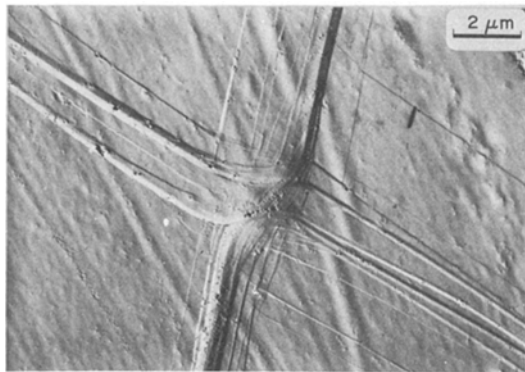


Figure 7 Electron micrograph of a replica of the first type of intersection.

can be calculated as a ratio of stretched (inside the intersection) and original (outside the intersection) striation lengths:

$$\sin(\theta + \cot^{-1}\gamma)/\cos(\theta/2),$$

where  $\theta$  is the acute angle of intersection or about  $79^\circ$  and  $\cot^{-1}\gamma$  is the acute angle between the striation and the band. This ratio is 1.25 for  $\theta = 79^\circ$  and  $\gamma = 2$ . In other words, the striation in the intersecting bands will be stretched up to 25% more during the intersecting process. Since the striation is already a stretched region in the coarse shear band, further stretching is difficult, as evidenced in the study of reformation [3]. Hence considerable efforts are needed for the bands to intersect each other.

The fact that there is a broad distribution of shear strain in one specimen shows that the striations are not regions in which all molecules are identically stretched. Even though the shear strain is uniform along a single band, not all striations are regions in which all molecules are stretched to their full capacity. Thus it is possible for some striations to stretch 25% more during

the intersection process. However, how many striations will be stretched or how extensive will be the region in which the molecules are stretched during intersection will depend on the local situation. The mutual displacement of the two bands will be small if the number of striations involved is small or the region affected is limited. Otherwise the mutual displacement of the two bands may be large. The latter is shown schematically in Fig. 11 for a larger band displacement than that shown in Fig. 10. It is seen that more striations are stretched in this intersection than the one shown in Fig. 10 in which the band displacement is smaller. However, most band displacements are not large. They are similar to the shear displacement in the band. Some measurements will be reported later.

After the intersection, the new band resumes its own direction of propagation. However, the situation is seldom as idealized as those shown in Figs. 10 and 11. The process of shearing through the old band is both difficult and chaotic. The appearance of the new band or bands after inter-

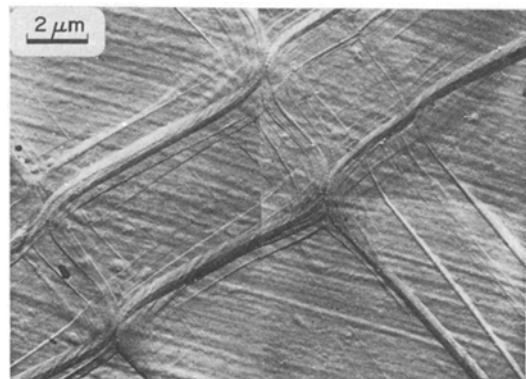
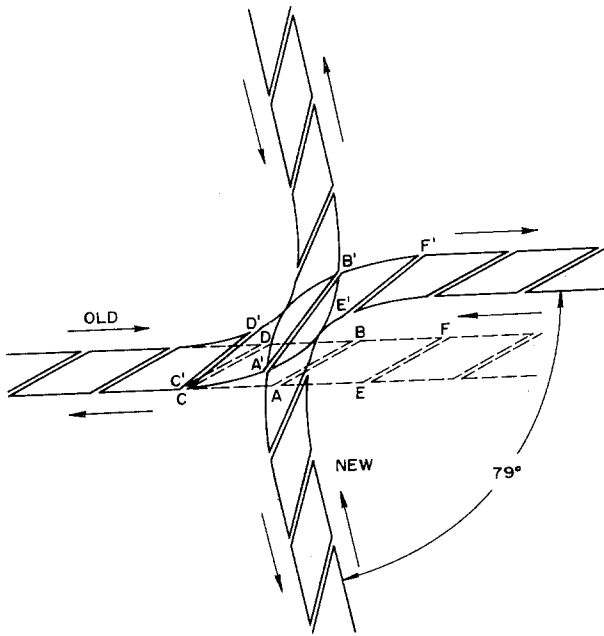


Figure 9 Distribution of striations in intersections of the first type (electron micrograph).

Figure 10 Schematic representation of the merging striations of the first type of intersection.



section may not resemble the band before intersection. Some splitting or joining may take place inside the intersection and some fine bands, and sometimes cracks, may be generated to relieve stresses. These are all seen in Figs. 7 and 8.

#### 4. The second type of intersection

The considerations shown in Figs. 10 and 11 suggest that there should be another type of intersection in which one of the shear strains is reversed. An examination of the intersections of the two band packets produced in a single compression reveals that they are all of the first type, the same as the ones just studied. To produce intersections of the second type, a special loading sequence is needed. Then both intersections may appear together. However, they can be differentiated by the shear displacement which each causes the other.

The loading sequence used is shown in Fig. 12. Fig. 12a shows the four sets of shear bands developed from a hole in the centre after the first compression. The specimen was then cut into two halves, through the hole, perpendicular to the compression direction. One of the halves is shown in Fig. 12b after polishing. A notch was introduced on the other side as shown in Fig. 12c, and the specimen was then compressed a second time, as shown in Fig. 12b, to produce two sets of new bands to intersect the two old ones. The intersections produced here are of the second type.

Note that the difference between Fig. 1 and Fig. 12d is that for Fig. 1 the two compressions were in the same direction while for Fig. 12d they are in mutually perpendicular directions. Since two sets of bands are produced in each compression and their intersection is of the first type, both kinds of intersection are present in Fig. 12d. However, as just mentioned, they can be differentiated.

The second type of intersection is shown in Fig. 13. It is seen that, as in the first type, the

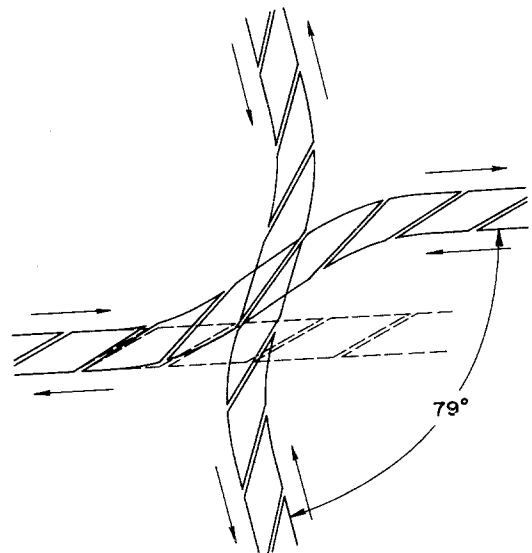


Figure 11 Schematic representation of large band displacement in intersections of the first type.

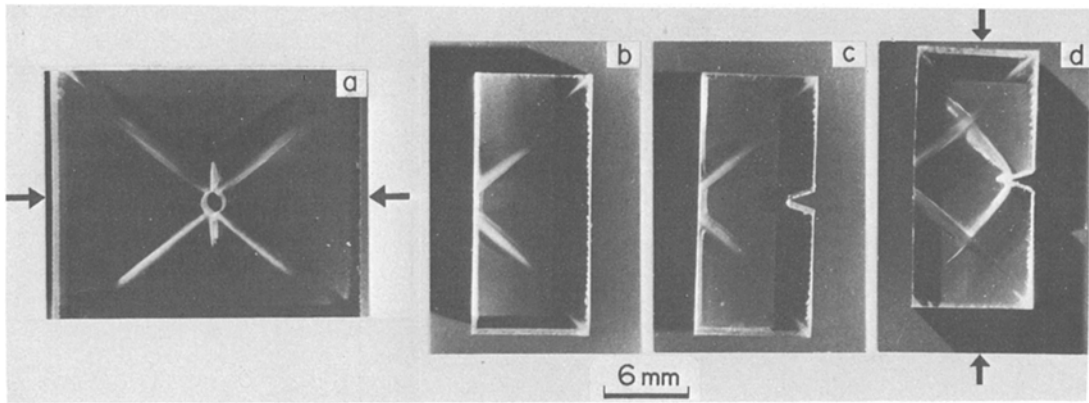


Figure 12 Experimental procedure for producing intersections of the second type.

two bands also shear each other. However, the relation between their shear vectors is different from the first type, and is shown in Fig. 14 which is to be differentiated from Fig. 10. The material in the intersection was first sheared by the old band and, unlike the situation in the first type, was sheared in reverse by the new band so that the net shear is reduced. When the two shear strains are about equal, the intersection may have the appearance of four broken-up half-bands as shown in Fig. 15. As in the case of the intersections of the first type, the two half-bands of similar thickness probably belong to the old band, the new band becomes thinner and splits into several bands after intersection. Another example is shown in Fig. 16. The single band is probably the old band. The new bands have about the same strain as the old band so that they both lose their appearances in the intersections.

Fig. 17 shows another example of the second type of intersection. The thin band is probably the old band. The new band seems to have felt the resistance of the old band at a distance and begun

to slow down. As a result, it split into many bands before intersection. Then after these bands reversed the shear strain of the old band so that the resistance decreased, the new band resumed its speed and propagated again as a single band.

Inspection of Fig. 14 shows that the material which occupied the space  $ABC'D'$  in the old band is sheared in reverse and stretched somewhat to occupy the space  $ABCD$  in the intersection. Obviously there is a decrease in density and microcracks are frequently seen, as shown in Fig. 18. Without microcracks this decrease in density could cause a depression on the surface. Although it is not obvious in Fig. 10 or 11, the reverse is true in the first type of intersection, i.e. there is an increase in density which could cause a bulge on the surface.

When the strains of the two bands are unequal, the material in the intersection may still be strained so that the band appearances remain. An example is shown in Fig. 19. The relative strains of the two bands are indicated by their displacements. It is seen that one is much larger than the other.

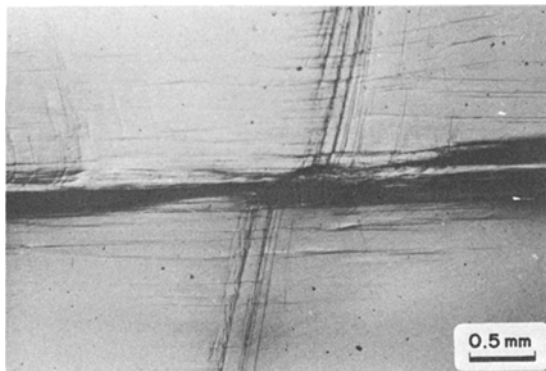


Figure 13 Intersecting band packets of the second type.

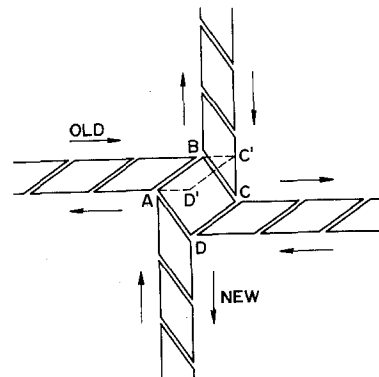
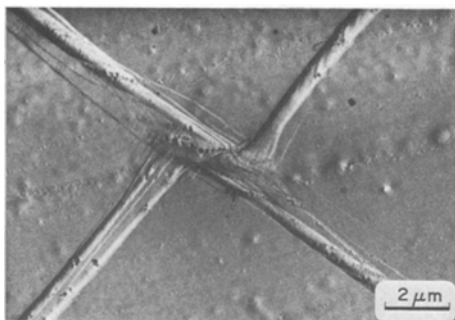
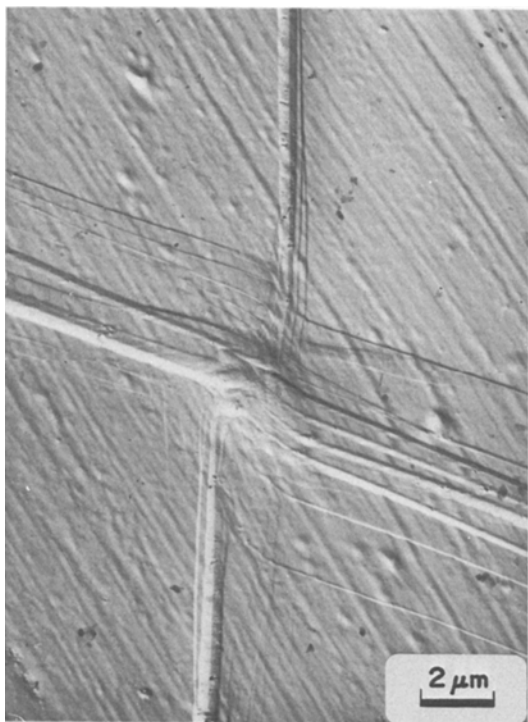


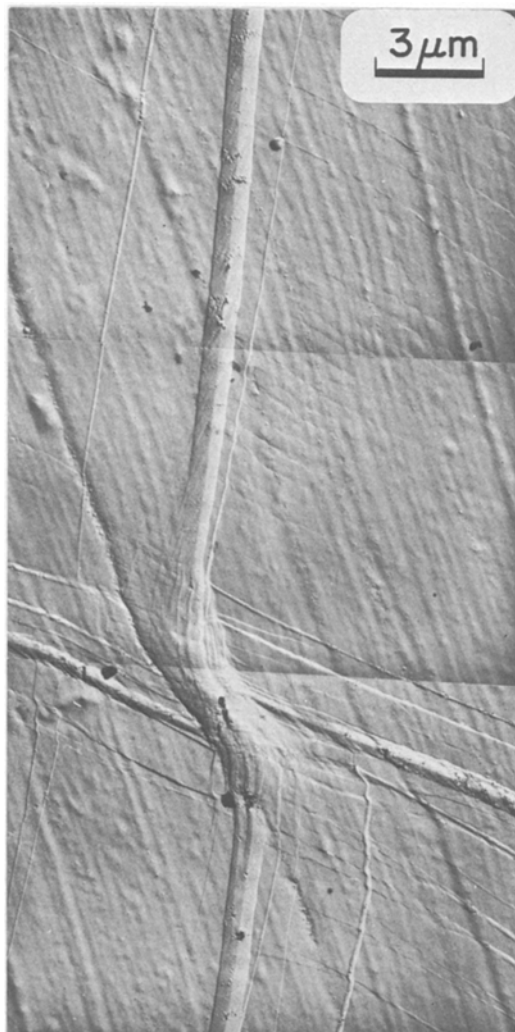
Figure 14 Schematic representation of the second type of intersection.



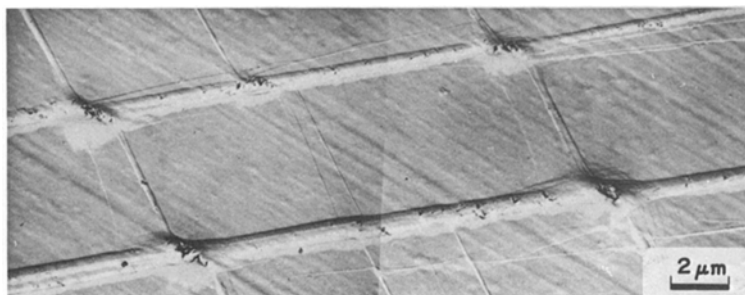
*Figure 15* Intersections of the second type showing four broken-up half-bands (electron micrograph).



*Figure 16* Disappearance of surface features in intersections of the second type (electron micrograph).

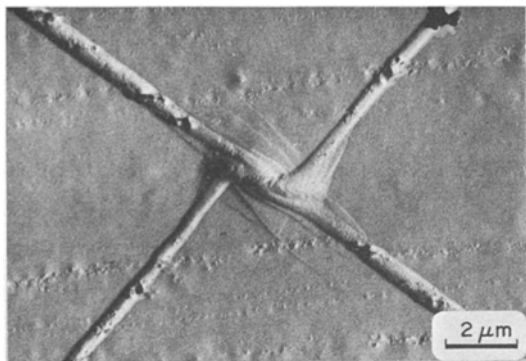


*Figure 17* Electron micrograph showing profuse splitting of a coarse band at an intersection of the second type and the recombination after intersection.



*Figure 18* Microcracks generated at intersections of the second type (electron micrograph).





*Figure 19* Surface features of the second type intersection when the shear strains of the two bands are not equal (electron micrograph).

The reason why the bands appear swollen is probably due to the splitting of bands near the intersection. Fig. 20 shows another example. The two thin bands actually propagated along the striations of the thick band and joined into one band after the intersection. Later the band appears to have entered another thick band along its striations but failed to emerge. These observations confirm our notion that the new band is sheared by the old band because the former is forced to propagate along the striations of the latter.

### 5. The third type of intersection

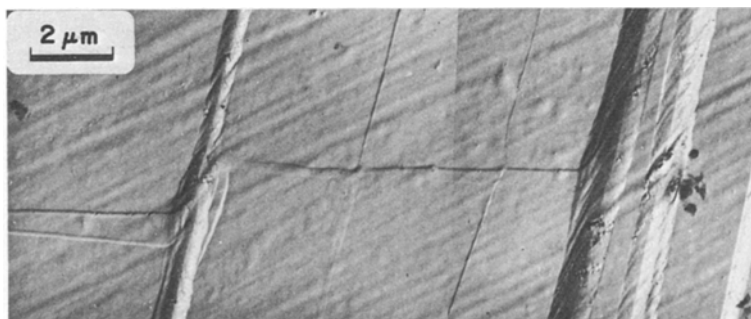
Since two mutually perpendicular compressions are necessary to produce the intersections of the second type, there are actually three different types of intersection among the four different coarse shear bands as shown in Fig. 21. The third type of intersection arises from the fact that the intersections of the first type are at  $79^\circ$  rather than  $90^\circ$ . Otherwise there would be only two types of intersection. However, because of local stress variations and strain recovery between and after compression, the observed angles of intersection may not be exactly as indicated in Fig. 21. Nevertheless, the angles of intersection of the

third type are much smaller than those of the other two types. Furthermore, since each band is near the striation direction of the other, the mutual resistance at the intersection is small. Some examples are shown in Fig. 22. It is seen that each band still displaces the other. Unlike the first two types of intersection, very little disturbance, such as the generation of many extra coarse or fine shear bands, is present at this kind of intersection. The new band simply bends slightly into the striation direction of the old band and propagates through it.

Another reason why the third type of intersection does not offer much resistance to either band is the reversal of shear strain in the intersection. The material is sheared by the old band but is sheared again largely in reverse by the new band. If the two shear strains are equal in magnitude, the resultant shear is very small. This explains the disappearance of surface features of some intersections as seen in Fig. 22. The disturbance at this intersection is obviously much less than that in the first and second types. In fact, it is so small that no new bands are generated in this intersection.

### 6. Strains measured by band displacements

To assess the mutual shearing effect quantitatively, we measured the shear strain of a band by the displacement of the other band wherever possible at the intersection and compared this to that measured by the displacement of scratches. Large uncertainties are involved because the band appearance is different before and after intersection. Some bending of bands may result because of local stresses. Comparison is also difficult because the scratch may be far away from the intersection. Nevertheless, the results as shown in Fig. 23 are consistent with the mutual shearing effect for all three types of intersection despite the unavoidable large scatter in each.



*Figure 20* Electron micrograph of an intersection of a thin band with a thick band showing the path of the thin band inside the thick band.

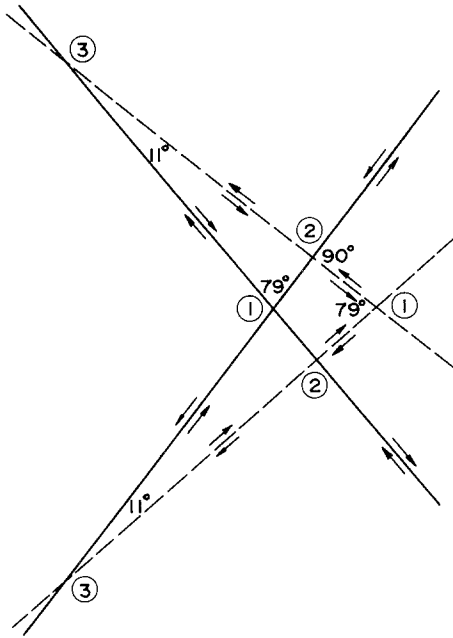


Figure 21 Intersections of all three types between shear bands produced by two mutually perpendicular compressions.

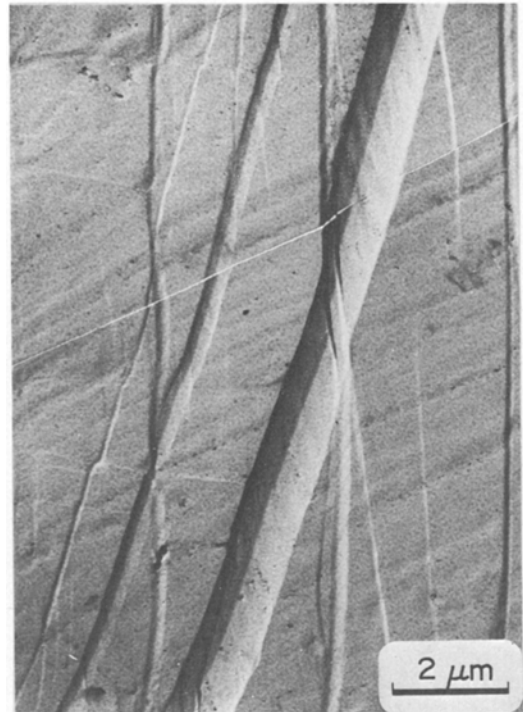


Figure 22 Electron micrograph of the third type of intersection.

## 7. Conclusions

(1) When a new coarse band intersects an existing old coarse band, the former not only shears the latter but is also sheared by it. The magnitude and direction of the second shear are about the same as those of the old band. The cause of the second shear can be traced to the structure of the old band, i.e. it seems easier for the new band to propagate along the striation directions of the old band rather than the original direction of the new band.

(2) The material inside the intersection is sheared twice, first by the old band and then by

the new band. From the way they shear each other two types of mutual shear are possible. The first type of intersection produces the two shears in nearly the same direction while the second type produces the two shears in opposite directions. In either case, the disturbances are sufficient to produce microcracks and other shear bands at the intersection.

(3) In intersections of the first type, the striations in both bands merge at the intersection. The molecules are stretched and their ability to stretch may affect the band displacement. The density of the material inside the intersection

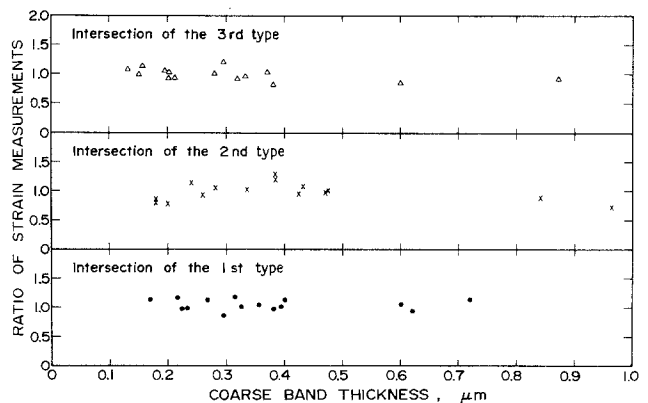


Figure 23 Comparison of shear strains measured by band displacement at intersections and by the displacement of scratches.

could be increased and/or a bulge could be formed on the surface.

(4) In the second type of intersection, the net strain in the intersection is smaller than the strain in either band. When it is very small, the surface features of the bands disappear at the intersection. The density of the material inside the intersection could be decreased, and/or a depression could be formed on the surface.

(5) A third type of intersection takes place also in two mutually perpendicular compressions. The angle of intersection is small in this case. The two shears are also in nearly opposite directions. The disturbance is so small that no microcracks or shear bands are produced and the two bands seem to offer little resistance to each other at this type of intersection.

(6) The mutual shearing effect at all three intersections is demonstrated quantitatively by comparing the shear strain calculated from band displacements and that from scratch displacements. The agreement is good within experimental error.

(7) These observations suggest that molecular ordering or directional defects exist in coarse shear bands in polystyrene.

## Acknowledgements

This work was supported by the US Army Research Office, Research Triangle Park, North Carolina, through contract DAAG 29-76-G-0314. The paper was written when Li was a senior Humboldt awardee at the Institut für Werkstoffe, Ruhr-Universität Bochum, Bochum, Germany.

## References

1. J. B. C. WU and J. C. M. LI, *J. Mater. Sci.* **11** (1976) 434.
2. J. C. M. LI and J. B. C. WU, *ibid* **11** (1976) 445.
3. C. C. CHAU and J. C. M. LI, *ibid* **14** (1979) 1593.
4. J. C. M. LI, *Met. Trans.* **9A** (1978) 1353.
5. B. T. A. CHANG and J. C. M. LI, to be published.
6. K. FRIEDRICH and K. SCHÄFER, *J. Mater. Sci.* **14** (1979) 480.
7. A. S. ARGON, R. D. ANDREWS, J. A. GODRICK and W. WHITNEY, *J. Appl. Phys.* **39** (1968) 1899.
8. T. E. BRADY and G. S. Y. YEH, *J. Appl. Phys.* **42** (1971) 4622; *J. Mater. Sci.* **8** (1973) 1083.
9. J. C. M. LI, C. A. PAMPILLO and L. A. DAVIS, in "Deformation and Fracture of High Polymers", edited by H. H. Kausch, J. A. Hassell and R. I. Jaffee, (Plenum Press, New York, 1973) pp. 239-58.

Received 21 November and accepted 5 December 1978.